

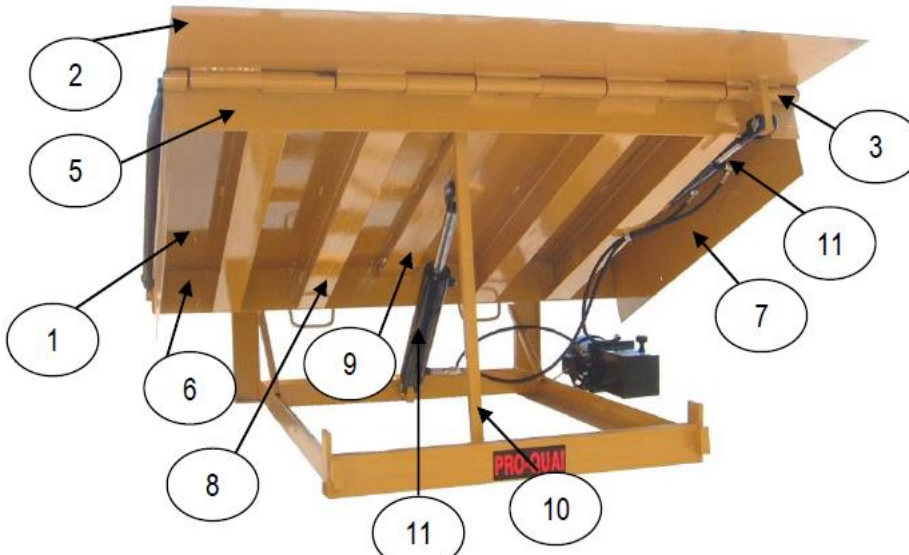

ULD7840



Technical Specifications

1. Top plate: checker plate 1/4"
2. Standard lip: checker plate 5/8" x 16"
3. Front piano hinge of 2 3/8" & 1 1/4" shaft
4. Rear piano hinge of 1 5/8" & 1" shaft
5. Front support flat bar: 6"
6. Rear support flat bar: 6"
7. Standard fixed toe guard
8. 6 H-Beam 6"@9.00 lbs/ft
9. 5" central channel
10. Standard maintenance stand
11. 1 Principal cylinder with anti-drop valve
1 Double action cylinder on the lip
12. Dimension : 7' x 8'
13. Dynamic load of 40 000 lbs

Distributor's informations

Name :

Phone :

Address :

Options

Voltage : Quantity :

Customer's informations

Name :

Phone :

Address :

Project Name :

Signature

ULD7840

Nominal pit size

Width	Length	Front height	Rear Height
7'	8'	20"	19,5"
2134 mm	2438 mm	508 mm	495 mm

Actual pit size

Width	Length	Front height	Rear height
85"	87"	20"	19,5"
2159 mm	2209 mm	508 mm	495 mm

Curb angles dimensions

Front width	91"	2312 mm
Rear width	91"	2312 mm
Length	84"	2133 mm
Height	20"	508 mm

When there is a downward slope towards the building, the dock leveler and the bumpers will be installed projecting outwards according to the slope's percentage.

Slope's %	Concrete's projection*	
2%	2 1/2"	64 mm
4%	6"	127 mm
6%	7 1/2"	191 mm
8%	10"	254 mm

Projection calculated from the back of the door seal

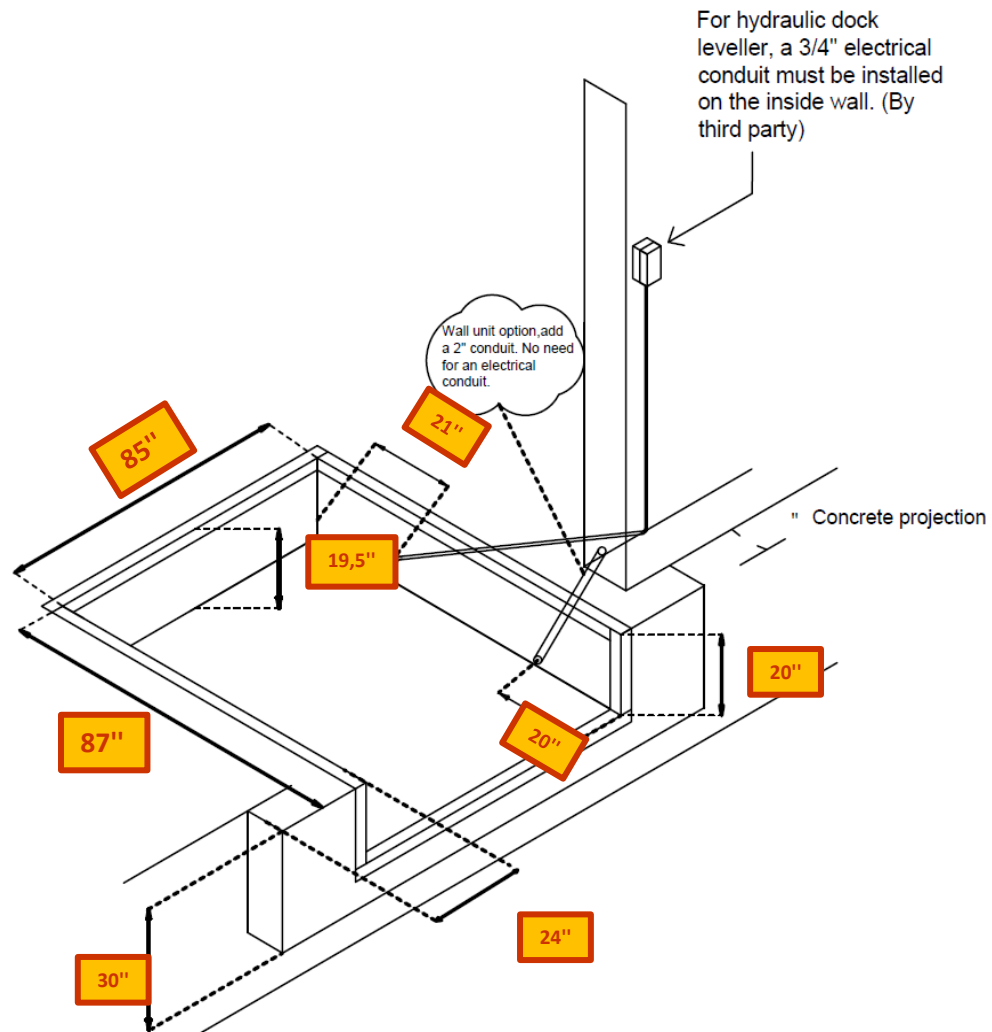

**If truck retrain, make concrete projection until footing.